



Fill-Line Breakaway (FLB-5000) - Heavy-Duty Truck/Bus

OPW has optimized the in-line breakaway for use in heavy-duty truck and bus NGV refueling applications. This unit will function consistently, independent of the inlet pressure.

Specifications:

Max Flow Rate: 7,500 SCFM @ 3,600 psid

Temperature Range: -40° F to 185° F
(-40° C to 85° C)

Cv: 3.91

MAWP: 4,532 psi (312.5 Bar)



Fill-Line Breakaway Kit

CNGBREAKKIT-5000
(Includes NGVLB Breakaway)

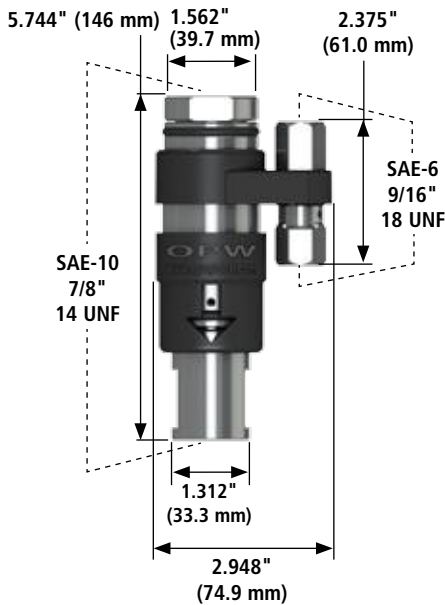

Materials

Body: Stainless steel

Internal Components: Stainless steel

Seals: Specially formulated polyurethane seals to withstand high pressure NGV applications



FLB-5000

Features

- ◆ **High-Flow/Fast Fill Capacity** - this is OPW's fastest flowing breakaway. This breakaway will provide quick fueling of large vehicles.
- ◆ **Durable, Corrosion-Resistant Construction** - stainless steel construction to provide improved durability and corrosion resistance in harsh environments.
- ◆ **Reconnectable Design** - allows the component to be reused, reducing total cost of ownership
- ◆ **Innovative Valve System** - the sealing system in this breakaway minimizes the amount of vent gas released during a drive-away incident.
- ◆ **Reduced Size and Weight** - to allow for more applications where size may be a concern.
- ◆ **Easy Installation** - the in-line breakaway has SAE-10 O-ring fittings for easy installation in line between the dispenser and nozzle.
- ◆ **Disconnection Force** - 120 +/- 30 lbs. (534 +/- 134 N).
- ◆ **100% Leak and Breakaway Tested, with Traceable Serial Numbers**

Ordering Specifications

Product #	Inlet Thread Size	Outlet Thread Size	Service Pressure	Weight
FLB-5000	SAE - 10, 7/8" - 14 UNF (female)	SAE - 10, 7/8" - 14 UNF (female)	3,600 psi 250 bar	2 lb (0.907 kg)
CNGBREAKKIT-5000 (Includes FLB-5000 and NGVLB Breakaway)	FLB-5000 SAE - 10, 7/8" - 14 UNF (female)	FLB-5000 SAE - 10, 7/8" - 14 UNF (female)	3,600 psi 250 bar	2.22 lb (1 kg)
	NGVLB SAE - 6, 9/16" - 18 UNF	NGVLB SAE - 6, 9/16" - 18 UNF	3,600 psi 250 bar	

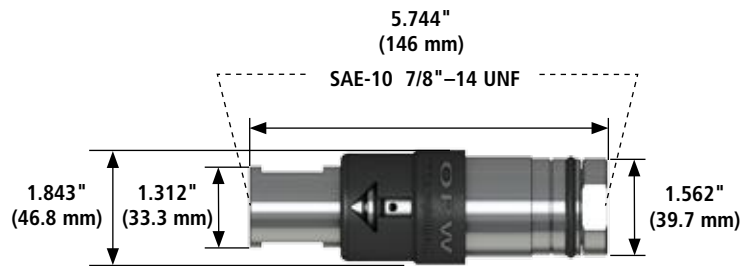

FLB-5000 Dimensions

Listings and Certifications



CE 0036

CRN

See page 33 for Canadian Registration Number

CleanEnergy Nozzle Compatibility Matrix



	CNG Nozzles	CNG Breakaways		NEW CNG Breakaways & CNGBREAKKITS			Standard NGV1 CNG Receptacles NOTE: These use Receptacle Fit Gage RINGO-0001						High Flow CNG Receptacles NOTE: These use Receptacle Fit Gage RINGO-0005						Nozzle Gages					
		ILB-1	ILB-5	FLB 1000 & CNG BREAK KIT-1000	FLB 5000 & CNG BREAK KIT-5000	NGVLB	LB30	LD30	LE30	LB36	LD36	LE36	CL40	CL4078	CL50	CL5000	CL5016	CL5078	JAWGO -1	JAWGO -5				
NGV1	Type 1	PGXXP30	✓	X	✓	X	✓	✓	✓	✓	✓	✓	✓	✓	✓	✓	✓	✓	✓	✓	✓	X		
		PGXXP36	✓	X	✓	X	✓	✓	✓	✓	✓	✓	✓	✓	✓	✓	✓	✓	✓	✓	✓	✓	X	
		CT1000SS (3,000 psi/ 200 bar)	✓	X	✓	X	✓	✓	✓	✓	✓	✓	✓	✓	✓	✓	✓	✓	✓	✓	✓	✓	✓	X
		CT1000P36S (3,600 psi/ 250 bar)	✓	X	✓	X	✓	X	X	X	✓	✓	✓	X	X	X	X	X	X	X	✓	✓	✓	X
	Type 2 & 3	CC300P30S (3,000 psi/ 200 bar)	✓	X	✓	X	✓	✓	✓	✓	✓	✓	X	X	X	X	X	X	X	✓	✓	✓	X	
		CC300P36S (3,600 psi/ 250 bar)	✓	X	✓	X	✓	X	X	X	✓	✓	X	X	X	X	X	X	X	✓	✓	✓	X	
		CC600S (3,000 psi/ 200 bar)	✓	X	✓	X	✓	✓	✓	✓	✓	✓	X	X	X	X	X	X	X	✓	✓	✓	X	
		CC600P36S (3,600 psi/ 250 bar)	✓	X	✓	X	✓	X	X	X	✓	✓	X	X	X	X	X	X	X	✓	✓	✓	X	
	Type 3	CC600 Series Nozzle including 3-Way Valve (3WV series) (3,600 psi/250 bar & 3,000 psi/200 bar)	✓	X	✓	X	✓	✓	✓	✓	✓	✓	X	X	X	X	X	X	X	✓	✓	✓	X	
		CC250 (3,000 psi/200 bar)	✓	X	✓	X	✓	✓	✓	✓	✓	✓	X	X	X	X	X	X	X	X	X	X	X	
Bus / High Flow	Type 1	CT5000S (3,600 psi/250 bar)	X	✓	X	✓	✓	X	X	X	X	X	X	X	X	X	X	X	✓	✓	✓	X		
	Type 2	CC6000 (3,600 psi/250 bar)	X	✓	X	✓	✓	X	X	X	X	X	X	X	X	X	X	X	✓	✓	✓	X		
CNG Defueling	BDN (3,600 psi/250 bar)	✓	X	✓	X	✓	✓	✓	✓	✓	X	X	X	X	X	X	X	X	✓	✓	✓	X		

CleanEnergy Hose Kit Compatibility Matrix

Fully Factory Assembled and Tested



			Time Fill			Light Duty (LD)					Heavy Duty (HD)		Extra Heavy Duty (XHD)	Defueling		
			2' Whip Hose / 14' Main Hose	2' Whip Hose / 18' Main Hose	8' Whip Hose / 12' Main Hose	2' Whip Hose / 8.3' Main Hose	2' Whip Hose / 8.3' Main Hose	2' Whip Hose / 10' Main Hose	2' Whip Hose / 13' Main Hose	2' Whip Hose / 13' Main Hose	2' Whip Hose / 8.3' Main Hose	2' Whip Hose / 8.3' Main Hose	2' Whip Hose / 8.3' Main Hose	10' Whip Hose / 2' Main Hose	25' Whip Hose / 25' Main Hose	
Hose Kit Component			TFCNG KIT-14C36	TFCNG KIT-20B36	TFCNG KIT-20D36	LDCNG KIT-11	LDCNG KIT-11 FLB	LDCNG KIT-12	LDCNG KIT-15A	LDCNG KIT-20B36	HDCNG KIT-11	HDCNG KIT-11FLB	XHDCNG KIT-10	LDCN DPK-12	XFLDCNG KIT-50	
Nozzles	NGV1	Type 1	PGXXP30	X	X	X	Contact OPW for Quote					X	X	X	X	X
		PGXXP36	X	X	X	Contact OPW for Quote					X	X	X	X	X	
		CT1000SS	X	X	X	X	X	X	✓	X	X	X	X	X	X	X
		CT1000P36S	X	X	X	✓	✓	✓	X	X	X	X	X	X	X	✓
	Type 2 & 3	CC600 Nozzle including 3-Way Valve	✓	✓	✓	X	X	X	X	✓	X	X	X	X	X	X
	Bus / High Flow	Type 1	CT5000S	X	X	X	X	X	X	X	X	✓	✓	✓	X	X
	Defueling	BDN	X	X	X	X	X	X	X	X	X	X	X	X	✓	✓ with 3WV-46D
Fill Line Break-aways	Standard Duty	ILB-1	X	X	X	✓	X	X	X	X	X	X	X	X	X	X
		FLB-1000	X	X	X	X	X	X	X	X	X	X	X	✓	X	
		CNGBREAK KIT-1000	✓	✓	✓	X	✓	✓	✓	✓	X	X	X	X	✓	
Fill Line Break-aways	Bus / High Flow	ILB-5	X	X	X	X	X	X	X	X	✓	X	X	X	X	X
		FLB-5000	X	X	X	X	X	X	X	X	X	X	X	X	X	X
		CNGBREAK KIT-5000	X	X	X	X	X	X	X	X	X	✓	✓	✓	X	X
Vent Line Breakaways	NGVLB	✓	✓	X	✓	X	✓	✓	✓	✓	✓	✓	X	✓		
Hose Retractor	6102-CNG	X	X	X	✓	✓	✓	✓	✓	X	X	X	X	X	✓	
	6102-CNG2	X	X	X	X	X	X	X	X	X	X	X	X	X	X	
	6102-CNG3	X	X	X	X	X	X	X	X	✓	✓	X	X	X	X	
	6102-CNG4	✓	✓	✓	X	X	X	X	X	X	X	X	X	X	X	

Canadian Registration Numbers by Province

Canadian Registration Numbers OPW CleanEnergy Products	British Columbia	Alberta	Ontario	Quebec	Saskatchewan	Manitoba	Nova Scotia	New Brunswick
PG series	pending	pending	pending	pending	pending	pending	pending	pending
CT1000 series	0H13989.51	0H13989.52	0H13989.5	0H13989.56	0H13989.56	0H13989.56	pending	pending
CT5000	0H15417.51	0H15417.52	0H15417.5	0H15417.56	0H15417.56	0H15417.54	0H15417.58ADD1	pending
CC600 series	0H13989.51	0H13989.52	0H13989.5	0H13989.56	0H13989.56	0H13989.56	pending	pending
ILB-1	0H13989.51	0H13989.52	0H13989.5	0H13989.56	0H13989.56	0H13989.56	pending	pending
ILB-5	0H15417.51	0H15417.52	0H15417.5	0H15417.56	0H15417.56	0H15417.56	pending	pending
VLB	0H13989.51	0H13989.52	0H13989.5	0H13989.56	0H13989.56	0H13989.56	pending	pending
FLB-1000 (new)	0H17341.51	0H17341.52	0H17341.5	0H17341.56	0H17341.56	0H17341.56	0H17341.5987	0H17341.5987
FLB-5000 (new)	0H17341.51	0H17341.52	0H17341.5	0H17341.56	0H17341.56	0H17341.56	0H17341.5987	0H17341.5987
NGVLB (new)	0H17341.51	0H17341.52	0H17341.5	0H17341.56	0H17341.56	0H17341.56	0H17341.5987	0H17341.5987
BDN	Pending	0H17140.2	Pending	Pending	Pending	Pending	Pending	Pending

TUV Approved

- ◆ PGXXP3X Series
- ◆ CT1000 series nozzles
- ◆ CT5000 series nozzles
- ◆ CC 200 series nozzles
- ◆ CC 300 series nozzles
- ◆ CC 600 series nozzles
- ◆ CC 6000 series nozzles
- ◆ ILB series breakaways
- ◆ FLB series breakaways
- ◆ NGVLB series breakaways
- ◆ LB, LD, LE series receptacles
- ◆ CL series receptacles